

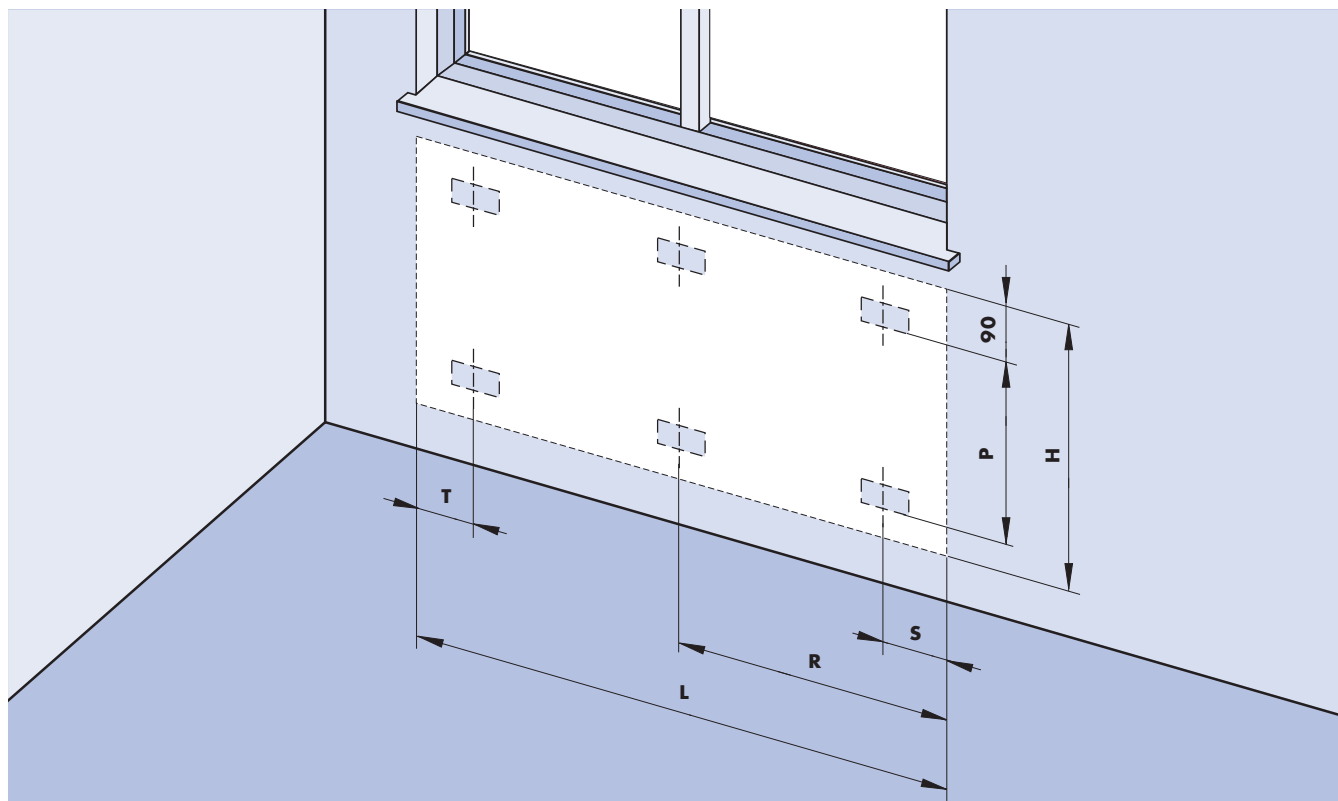

# KORAMONT® MOUNTING OF RADIK STEEL PANEL RADIATORS

## DATA FOR FIXING



		Radiator length L [mm]						
Type		400	500 ÷ 1600	1800	2000	2300	2600	3000
<b>S</b> [mm]	10, 20, 20S, 20 VK, 20 VKL, 20S VK, 20 MM, 21, 21 VK, 21 VKL, 21 MM, 22, 22 VK, 22 VKL, 22 COMBI VK, 22 MM, 30, 30 VK, 33, 33 VK, 33 VKL, 33 MM	133	133	133	133	133	133	133
	10 VK	167	167	167	167	167	167	167
	10 VKL	100	133	133	133	133	133	133
	10 MM	-	133	133	133	-	-	-
	11,11 VK, 11 VKL, 11 MM	117	150	150	150	150	150	150
<b>T</b> [mm]	10, 20, 20S, 20 VK, 20 VKL, 20S VK, 20 MM, 21, 21 VK, 21 VKL, 21 MM, 22, 22 VK, 22 VKL, 22 COMBI VK, 22 MM, 30, 30 VK, 33, 33 VK, 33 VKL, 33 MM	133	133	133	133	133	133	133
	10 VK	100	133	133	133	133	133	133
	10 VKL	167	167	167	167	167	167	167
	10 MM	-	133	133	133	-	-	-
	11,11 VK, 11 VKL, 11 MM	117	150	150	150	150	150	150
<b>R</b> [mm]	10, 20, 20S, 20 VK, 20 VKL, 20S VK, 20 MM, 21, 21 VK, 21 VKL, 21 MM, 22, 22 VK, 22 VKL, 22 COMBI VK, 22 MM, 30, 30 VK, 33, 33 VK, 33 VKL, 33 MM	-	-	900	1000	1133	1300	1500
	10 VK, 10 VKL	-	-	900	1000	1133	1300	1500
	10 MM	-	-	-	-	-	-	-
	11,11 VK, 11 VKL, 11 MM	-	-	833	983	1150	1283	1483

### Notice:

PLAN KLASIK = HYGIENE = CLEAN = KLASIK - R = KLASIK

PLAN VK = HYGIENE VK = CLEAN VK = VKM = PLAN VKL = VK

PLAN 11 VKL = 11 VKL

H [mm]	300	400	500	554	600	900
P [mm]	145	245	345	399	445	745