

RADIK **PREMIUM**

design steel panel radiators





Focused on design

KORADO range of premium products has been developed in order to satisfy the requirements of even the most demanding customers. The design radiators included in this range are especially intended for modern interiors, where the overall aesthetic impression plays a primary role. The large variety of shapes, designs and colours makes these products suitable for heating atypical spaces. Don't limit your choices. Choose what suits you best. Our premium range gives you the opportunity to make that choice!



RADIK PLAN PREMIUM

RADIK PLAN PREMIUM is a vertically aligned steel panel radiator in the PLAN design, i.e. it has a flat front panel. Its design enables it to be connected to a pressurised heating system primarily from the middle bottom or side bottom.



RADIK LINE PREMIUM

RADIK LINE PREMIUM is a vertically aligned steel panel radiator in the LINE design, i.e. it has a flat front panel with fine vertical grooves. Its design enables it to be connected to a pressurised heating system from the middle bottom or side bottom.



RADIK PREMIUM

RADIK PREMIUM is a vertically aligned steel panel radiator with a traditionally profiled front panel with vertically and horizontally arranged channels. Its design enables it to be connected to a pressurised heating system from the middle bottom or side bottom.

RADIK PREMIUM



Description

The model **RADIK PREMIUM** is a vertically aligned radiator. The dimensions of this model make it ideal for use in tight or atypical rooms. Its design enables it to be connected primarily from the **middle bottom** or **side bottom** to a pressurised heating system. Alternatively, you can also use its top middle and top side connections. There are no hangers welded on the back side therefore the radiator is supplied with special brackets, guaranteeing an easy, fast and safe mounting. Apart from type 10, all other radiator types come fitted with side covers.

Overview of types

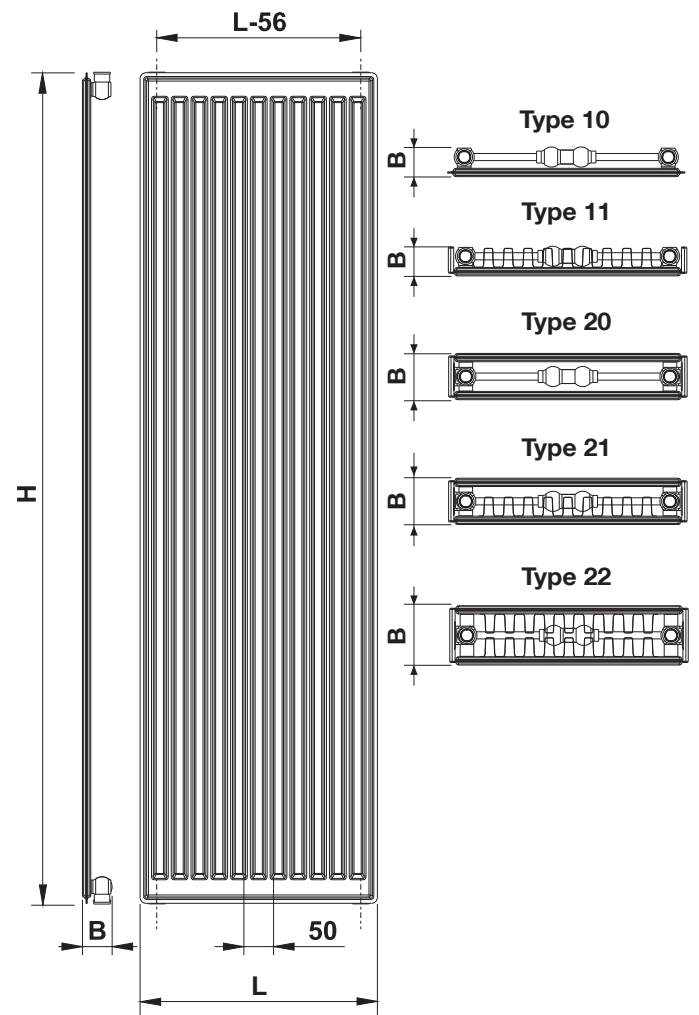

Technical data

Height H	1600, 1800, 2000, 2200 mm
Length L	400, 500, 600, 700 mm
Depth B	
Type 10	47 mm
Type 11	47 mm
Type 20	77 mm
Type 21	77 mm
Type 22	100 mm
Connecting pitch	50 mm
Connecting thread	6 x G1/2 inside
Highest allowed working pressure	10 bar
Highest allowed working temperature	110 °C
Radiator connection	middle bottom, side bottom, middle top, side top
Resistance coefficient	
Type 10, 11	$\xi_T = 8$
Type 20, 21, 22	$\xi_T = 12$

Examples of connection to the heating system

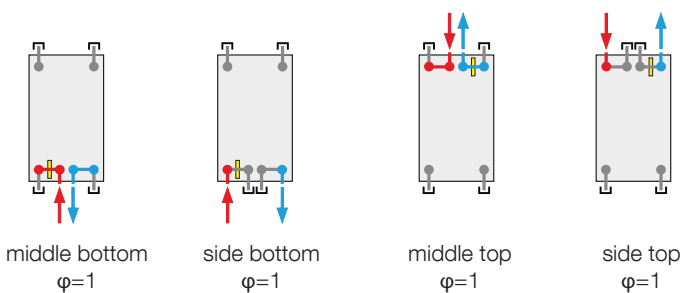

RADIK PLAN PREMIUM



Technical data

Height H	1600, 1800, 2000, 2200 mm
Length L	400, 500, 600, 700 mm
Depth B	
Type 11 PLAN	49 mm
Type 20 PLAN	79 mm
Type 21 PLAN	79 mm
Type 22 PLAN	102 mm
Connecting pitch	50 mm
Connecting thread	6 x G1/2 inside
Highest allowed working pressure	10 bar
Highest allowed working temperature	110 °C
Radiator connection	middle bottom, side bottom, middle top, side top
Resistance coefficient	
Type 11	$\xi_T = 8$
Type 20, 21, 22	$\xi_T = 12$

Description

The model **RADIK PLAN PREMIUM** is a vertically aligned radiator **with a flat front panel**. The dimensions of this model make it ideal for use in tight or atypical rooms. Its design enables it to be connected primarily from the **middle bottom or side bottom** to a pressurised heating system. Alternatively, you can also use its top middle and top side connections. There are no hangers welded on the back side therefore the radiator is supplied with special brackets, guaranteeing an easy, fast and safe mounting. All radiator types are fitted with side covers.

Overview of types

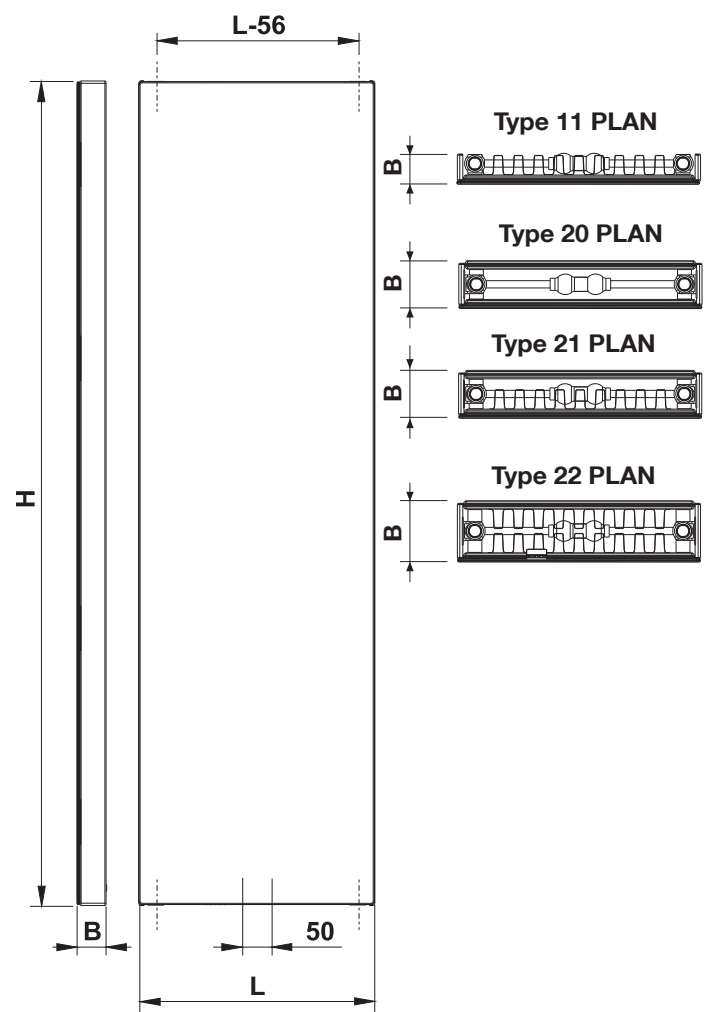

Examples of connection to the heating system

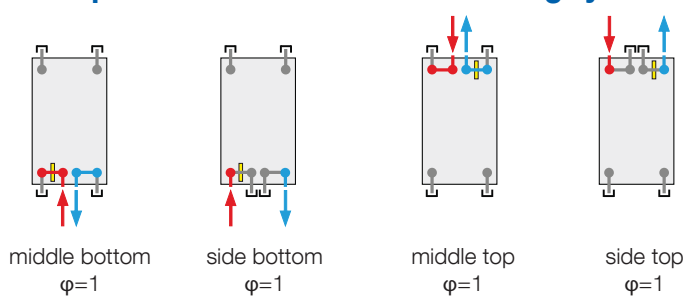

RADIK LINE PREMIUM



Technical data

Height H	1600, 1800, 2000, 2200 mm
Length L	400, 500, 600, 700 mm
Depth B	
Type 11 LINE	49 mm
Type 20 LINE	79 mm
Type 21 LINE	79 mm
Type 22 LINE	102 mm
Connecting pitch	50 mm
Connecting thread	6 x G1/2 inside
Highest allowed working pressure	10 bar
Highest allowed working temperature	110 °C
Radiator connection	middle bottom, side bottom, middle top, side top
Resistance coefficient	
Type 11	$\xi_T = 8$
Type 20, 21, 22	$\xi_T = 12$

Description

The model **RADIK LINE PREMIUM** is a vertically aligned radiator with a flat front panel with fine vertical grooves. The dimensions of this model make it ideal for use in tight or atypical rooms. Its design enables it to be connected primarily from the **middle bottom or side bottom** to a pressurised heating system. Alternatively, you can also use its top middle and top side connections. There are no hangers welded on the back side therefore the radiator is supplied with special brackets, guaranteeing an easy, fast and safe mounting. All radiator types are fitted with side covers.

Overview of types

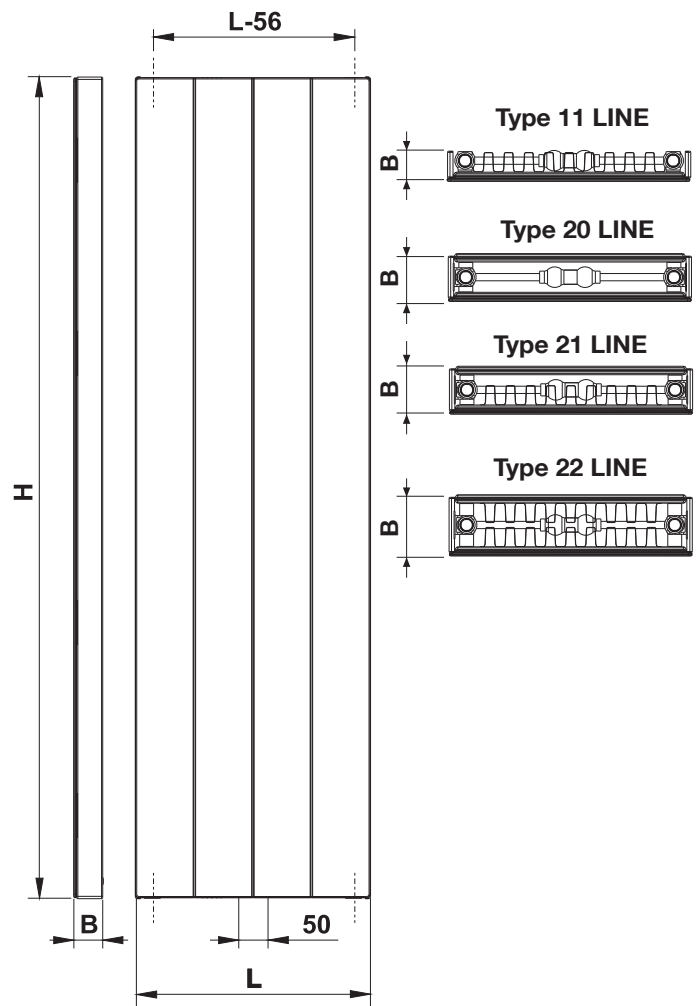

Examples of connection to the heating system

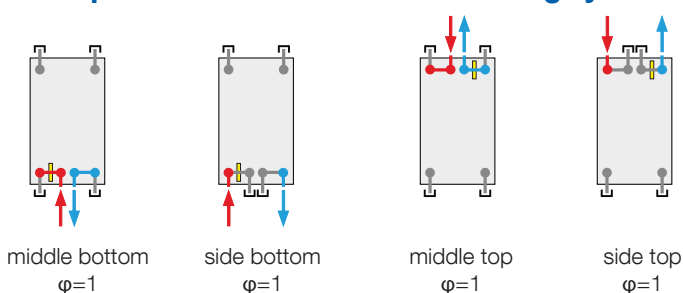

RADIK PREMIUM - HEAT OUTPUTS AND BASIC TECHNICAL PARAMETERS



20 °C		Type 10				Type 11				Type 20				Type 21				Type 22			
Length L [mm]	t ₁ /t ₂ [°C]	Height H [mm]																			
		1600	1800	2000	2200	1600	1800	2000	2200	1600	1800	2000	2200	1600	1800	2000	2200	1600	1800	2000	2200
400	90/70	846	943	1044	1152	1101	1213	1322	1427	1319	1456	1584	1719	1543	1696	1835	1974	1850	2019	2189	2359
	75/65	671	745	823	906	863	952	1038	1121	1037	1146	1248	1356	1212	1332	1440	1548	1452	1584	1716	1848
	70/55	545	604	666	731	694	766	837	904	837	926	1009	1098	977	1074	1160	1247	1170	1276	1381	1487
	55/45	350	386	423	462	436	482	527	570	528	586	640	698	616	676	730	784	737	803	868	933
500	90/70	1058	1178	1305	1440	1376	1516	1653	1783	1649	1820	1980	2148	1928	2120	2294	2467	2312	2524	2736	2948
	75/65	839	932	1029	1133	1079	1190	1298	1401	1296	1433	1560	1695	1515	1665	1800	1935	1815	1980	2145	2310
	70/55	682	755	833	914	868	958	1046	1130	1046	1157	1262	1372	1222	1342	1450	1558	1463	1595	1727	1859
	55/45	437	482	529	578	545	602	658	712	660	732	800	873	771	846	913	980	921	1003	1085	1166
600	90/70	1269	1414	1566	1728	1651	1820	1983	2140	1978	2184	2376	2578	2314	2545	2752	2960	2774	3029	3283	3538
	75/65	1006	1118	1235	1359	1294	1427	1557	1681	1555	1719	1872	2034	1818	1998	2160	2322	2178	2376	2574	2772
	70/55	818	907	999	1097	1042	1150	1255	1356	1255	1389	1514	1647	1466	1611	1740	1870	1755	1914	2072	2230
	55/45	525	579	634	693	654	723	790	855	792	879	960	1047	925	1015	1095	1176	1105	1204	1302	1400
700	90/70	1481	1650	1827	2016	1926	2123	2314	2497	2308	2548	2772	3008	2700	2969	3211	3454	3237	3533	3830	4127
	75/65	1174	1304	1441	1586	1510	1665	1817	1961	1814	2006	2184	2373	2121	2331	2520	2709	2541	2772	3003	3234
	70/55	954	1058	1166	1280	1215	1341	1464	1582	1464	1620	1766	1921	1711	1879	2030	2182	2048	2233	2418	2602
	55/45	612	675	740	809	763	843	922	997	924	1025	1120	1222	1079	1184	1278	1372	1290	1404	1519	1633
Nominal heat output [W/m]		1677	1863	2058	2265	2157	2379	2595	2802	2592	2865	3120	3390	3030	3330	3600	3870	3630	3960	4290	4620
Temp. exponent n [-]		1.2748	1.2892	1.3037	1.3182	1.3361	1.3320	1.3278	1.3237	1.3202	1.3135	1.3068	1.3000	1.3235	1.3263	1.3292	1.3320	1.3276	1.3310	1.3344	1.3379
Radiator weight [kg/m]		30.9	34.5	38.1	42	42.9	48.3	53.7	57.9	63.3	71.1	78.6	87.6	71.7	80.1	89.1	98.4	80.7	88.8	96.6	108.9
Water volume [l/m]		7.2	8.4	9.3	10.2	7.2	8.4	9.3	10.2	14.1	16.2	18	20.1	14.1	16.2	18	20.1	14.1	16.2	18	20.1

RADIK PLAN/LINE PREMIUM - HEAT OUTPUTS AND BASIC TECHNICAL PARAMETERS

20 °C		Type 11 PLAN Type 11 LINE				Type 20 PLAN Type 20 LINE				Type 21 PLAN Type 21 LINE				Type 22 PLAN Type 22 LINE			
Length L [mm]	t ₁ /t ₂ [°C]	Height H [mm]															
		1600	1800	2000	2200	1600	1800	2000	2200	1600	1800	2000	2200	1600	1800	2000	2200
400	90/70	1008	1099	1184	1263	1238	1349	1452	1544	1434	1563	1677	1776	1712	1883	2047	2200
	75/65	795	867	935	999	974	1064	1147	1224	1128	1231	1322	1401	1343	1477	1605	1728
	70/55	643	702	757	811	787	861	930	995	911	995	1070	1134	1082	1189	1292	1393
	55/45	408	446	482	519	498	547	592	638	576	630	679	721	680	747	811	878
500	90/70	1260	1373	1480	1578	1547	1687	1815	1930	1793	1954	2096	2220	2140	2354	2559	2750
	75/65	994	1084	1169	1249	1218	1330	1434	1530	1410	1539	1653	1752	1679	1846	2006	2160
	70/55	804	877	947	1014	983	1076	1162	1244	1138	1244	1337	1418	1352	1486	1615	1742
	55/45	510	558	603	649	622	683	741	798	720	788	849	901	851	934	1014	1098
600	90/70	1512	1648	1776	1894	1856	2024	2179	2317	2151	2345	2515	2664	2568	2825	3071	3300
	75/65	1192	1300	1402	1499	1461	1596	1721	1836	1692	1847	1983	2102	2015	2215	2407	2592
	70/55	964	1053	1136	1217	1180	1291	1395	1492	1366	1493	1604	1701	1623	1784	1938	2090
	55/45	612	669	724	778	747	820	889	957	863	946	1019	1081	1021	1121	1217	1317
700	90/70	1764	1923	2072	2209	2166	2362	2542	2703	2510	2736	2934	3109	2996	3295	3582	3850
	75/65	1391	1517	1636	1749	1705	1862	2008	2142	1974	2155	2314	2452	2351	2584	2808	3024
	70/55	1125	1228	1325	1419	1377	1506	1627	1741	1594	1741	1872	1985	1893	2081	2261	2438
	55/45	714	781	844	908	871	957	1037	1117	1007	1103	1189	1262	1191	1308	1420	1537
Nominal heat output [W/m]		1987	2167	2337	2498	2435	2660	2868	3060	2820	3078	3305	3503	3358	3692	4012	4320
Temp. exponent n [-]		1.3044	1.2997	1.2950	1.2830	1.3136	1.3037	1.2937	1.2751	1.3169	1.3102	1.3034	1.3011	1.3312	1.3331	1.3349	1.3251
Radiator weight [kg/m]		55.7	62.7	69.7	75.5	76.1	85.5	94.6	105.2	84.5	94.5	105.1	116	93.5	103.2	112.6	126.5
Water volume [l/m]		7.2	8.4	9.3	10.2	14.1	16.2	18	20.1	14.1	16.2	18	20.1	14.1	16.2	18	20.1

GENERAL INFORMATION

Use

RADIK PREMIUM steel panel radiators are designed to be mounted as part of a central heating system with a highest allowed working pressure of 10 bar, in which water or a water solution is used as the heat-carrying medium with a highest allowed working temperature of 110 °C. They are intended for two-pipe pressurised water systems. Radiators must be installed by professional plumbers in hot water heating systems that have been professionally installed according to VDI 2035 with regard to the protection against damage caused by corrosion and limescale.

The following main water quality attributes must be adhered to:

- pH range 8.5 - 9.5 (this applies for systems which do not contain aluminium),
- overall water hardness (contents of Ca + Mg ions) up to 1 mmol/l,
- salinity within the range of 300 – 500 µS/cm,
- oxygen content max. 0.1 mg/l.

Surface finish

RADIK PREMIUM radiators are coated with two layers of paint. The first layer consists of the cataphoretic paint (KTL), while the upper layer consists of epoxy polyester powder paint. The basic colour is White RAL 9016. You can order your radiator to be supplied in other colours by picking from the colour chart.

Basic equipment

All radiators are equipped with an air vent and the respective number of blanking plugs. Mounting brackets are delivered as standard.

Related norms

ČSN EN 442
DIN EN 442
ČSN 06 1101
ČSN 06 1122
ČSN 06 0310
ČSN 07 7401
DIN 55 900

Overview of types

Type	Number of panels	Number of convector fins
Type 10	1	0
Type 11	1	1
Type 20	2	0
Type 21	2	1
Type 22	2	2

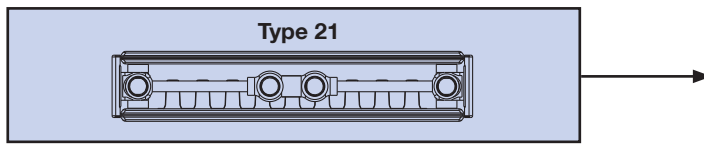

POSITION OF RADIATOR

RADIK PREMIUM

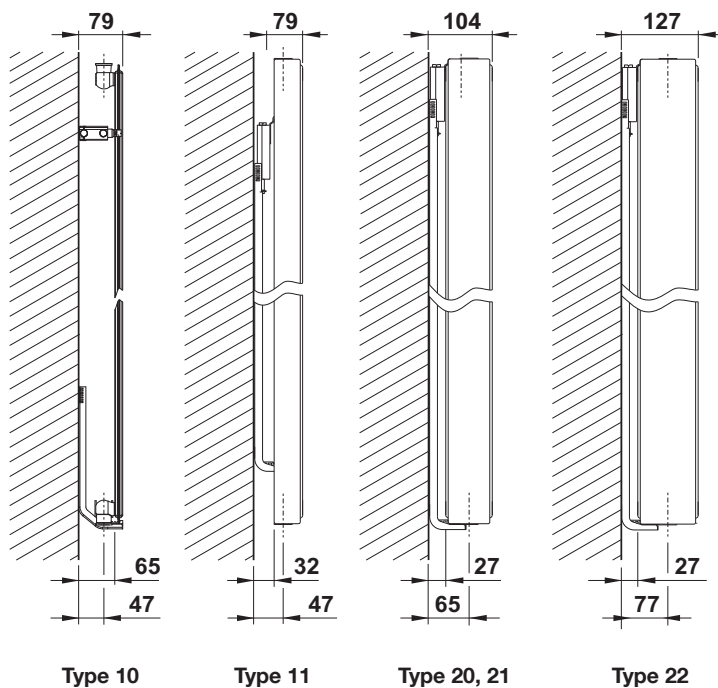

RADIK PLAN/LINE PREMIUM

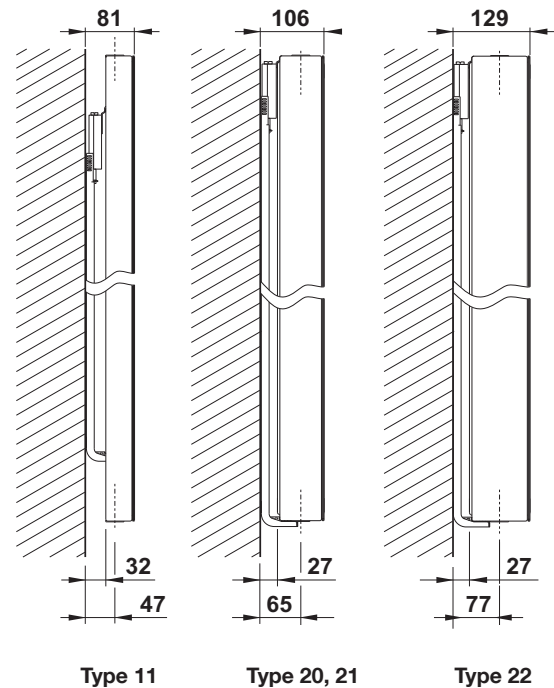



- Quality management system according to ISO 9001:2008

Quality of RADIK steel panel radiators



Our QMS in accordance with ISO 9001:2008 guarantees that KORADO customers always receive products and services with a high and consistent level of quality.

RADIK steel panel radiators - safety and conformity with European directives and standards

- European standard EN 442 for radiators



- by using CE mark the producer confirms that the radiators are in conformity with the characteristics stated in the Declaration of Performance issued in conformity with the Regulation (EU) of the EP and the Council No. 305/2011. This conformity has been confirmed by the notified body No. 1015, Strojirenský zkušební ústav s.p. Brno.



DATA FOR PLACING ORDERS

Model	Type	Code for ordering
RADIK PREMIUM	10	10-HHHLLL-W0-10
	11	11-HHHLLL-W0-10
	20	20-HHHLLL-W0-10
	21	21-HHHLLL-W0-10
	22	22-HHHLLL-W0-10
RADIK PLAN PREMIUM	11	11-HHHLLL-W0H10
	20	20-HHHLLL-W0H10
	21	21-HHHLLL-W0H10
	22	22-HHHLLL-W0H10
RADIK LINE PREMIUM	11	11-HHHLLL-W0I10
	20	20-HHHLLL-W0I10
	21	21-HHHLLL-W0I10
	22	22-HHHLLL-W0I10

Scheme for the creation of a code

TT-HHHLLL-MM-10

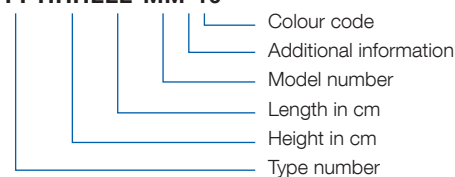

Example for creating a code

RADIK PREMIUM steel panel radiator
type 22, height H = 1800 mm, length L = 600 mm,
colour White RAL 9016

Correct code: 22 - 180060 - W0 - 10

COLOUR CARD



Notice:

The colour of the radiator may vary in comparison with the colour shown in the colour card.
The standard paint finish is RAL 9016, other colours from KORADO colour range with an extra charge 30 %.
Radiators can be ordered also in other colours from RAL colour range with an extra charge 40 %.

The company reserves the right to make technical changes.

NOTES



KORADO, a.s.
Bří Hubálků 869
560 02 Česká Třebová
Czech Republic

e-mail: info@korado.cz
www.korado.com

Ev. č.: 07/16.980.0. EN